



REHAU WINDOW SYSTEMS

QUALITY YOU CAN COUNT ON

REHAU

REDEFINING QUALITY, FORGING PARTNERSHIPS

A pioneer and leader in polymer processing technology

In 2008, REHAU celebrated its 60th anniversary. It celebrated its reputation for innovation, trust and quality in developing a wide range of products and services for the construction, automotive and industrial sectors.

With more than 15,000 employees around the globe in over 170 locations on 5 continents, REHAU offers unparalleled expertise in materials development, systems design and surface technology, and an unwavering commitment to building long-lasting partnerships and alliances with our customers.

Continuing research and development enables us to consistently deliver cost-effective and environment-friendly products. Stringent quality control and safety guidelines ensure that all our products comply with the highest international standards. REHAU's products and systems for the window and door, heating and plumbing, fire protection and pipe markets complement each other in integrated high-performance solutions, representing the perfect blend of quality and innovation to inspire better living.





Why REHAU Window Systems?

What you need, what every fabrication needs is a supplier that has the best in products, provides business and marketing support that is unsurpassed and stands by you every step of the way. With our German engineered products, our local but internationally experienced support staff and our muscle backing you all the way to the top, you can rest assured of a successful business venture.



Global brand appeal with local broad-based support

As a window fabricator, you couldn't ask for an easier sell than REHAU. On one hand, this is a **globally acclaimed** brand that needs little introduction among those familiar with quality German engineering. On the other, REHAU operates a **worldwide network** of regional and local sales offices that ensure both retailers and consumers enjoy the **best after-sales service** possible. Add the well earned reputation for quality that the REHAU brand enjoys globally, and you have a product that virtually sells by itself!



Quality and certification

REHAU Window Systems meet international quality and regulatory standards, and are accredited by both international and national regulatory bodies.

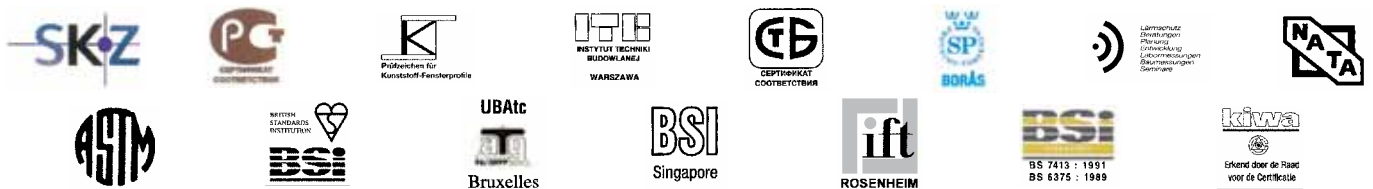

CUSTOMER SATISFACTION WITH EASE

SLEEK AND SOLID WINDOWS THAT ARE A BREEZE TO INSTALL

- 1 Improved multi-chamber design
- 2 Enlarged reinforcement chamber
- 3 Welded corners
- 4 Protective seals
- 5 Easy glazing
- 6 Smooth and effortless operation
- 7 In-board eurogroove
- 8 Effective sealing



REHAU Euro-Design Slide



REHAU-Prestige-Design

	REHAU uPVC	Aluminum	Wood
Thermal Insulation	Very good. Heat losses are reduced due to wider profile depth & multi chamber section and low K value.	Poor. Being a metal it has a poor thermal insulation, and high thermal conductivity.	Fair
Eco-friendliness	Excellent	Require 7.5 times the energy than that required to manufacture uPVC.	-
Maintenance	Very low maintenance required	Low maintenance required. Corrodes easily.	Require regular painting & polishing
Sound	35% better insulation	Fair	Fair

HIGH
QUALITY
PROFILE

EASY
FABRICATION

FAST

DESIGN
FLEXIBILITY

SOUND
INSULATION

HEAT
RESISTANCE

IMPROVED
SECURITY

SUPERIOR
AIR AND
WATER
TIGHTNESS

UNRIVALLED BENEFITS + EASY INSTALLATION

With REHAU Euro-Design Slide and REHAU Prestige-Design, customers have a **comprehensive range** of sleek casement, sliding and tilt-and-turn windows to choose from. And because these different systems sport a **uniform profile depth** of 60mm, they can be **mixed and matched** for side-by-side installation to suit the users' needs or design considerations. This gives REHAU window systems an attractive selling point with homeowners and architects alike.

Mix & match and save up to 10% on inventory

Residential Doors



single door French door single/fix combination bi-fold doors

Sliding Doors



double slider 4-panel

Sliding Windows



single slider double slider 3-panel

Inward Opening Windows



tilt-and-turn folding-sliding inward span with top arch window

Outward Opening Windows



slide-hung top-hung side-hung / top-hung combination

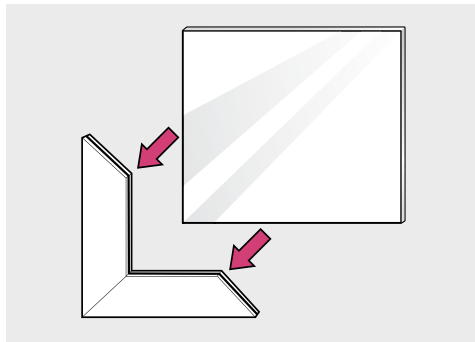

EASY GLAZING

- Proven REHAU single-leg design – key to safe and fuss-free glazing
- Safety and reliability doubled due to glazing depth of at least 20mm
- Glazing bead design makes it fast and simple to upgrade or replace window glass

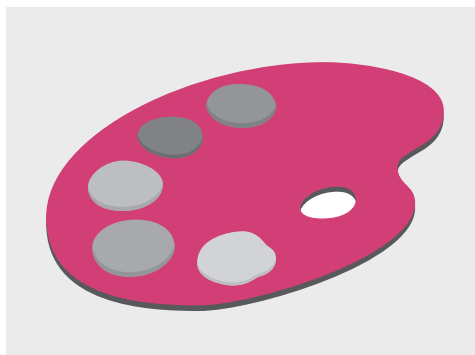

ADDING COLOUR TO THE WORLD

In addition to their renowned gloss and clean lines, our profiles come in a **wide range of colours** to cater to every preference and painted setting. White, Oyster white, brown and caramel coloured base bodies are available. Golden Oak, Macore, Grey and Ceylon coloured foils are offered as standard options. A plethora of other colours are offered on request.

More than 10 coloured foils available

THE REHAU ADVANTAGE

CONTINUOUS VALUE CREATION FOR YOUR CUSTOMER

Creating more value is part of the long held REHAU culture. What you offer your customers is directly related to how well you do.

35% better sound insulation*

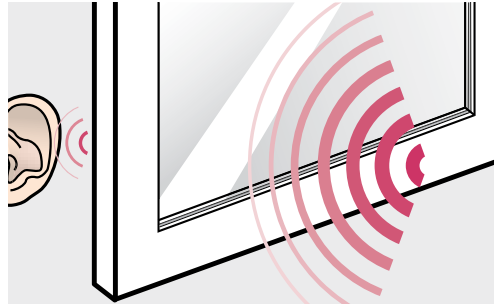

IMPROVED MULTI-CHAMBER DESIGN

- Reduced sound transmission by up to 40dB due to effective sealing
- Comfort and peace even with the most congested of traffic outside

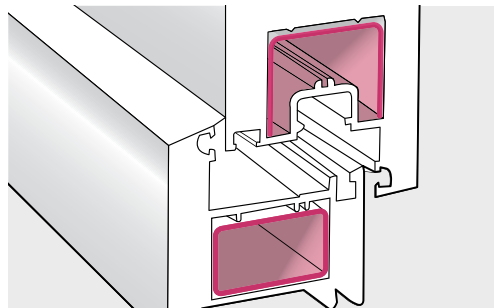

ENLARGED REINFORCEMENT CHAMBER

- Provides resistance to high wind pressure
- Up to 6300 Pa; 270-380km/h of wind resistance
- Accommodates a wide selection of designs
- Suitable for high-rise projects

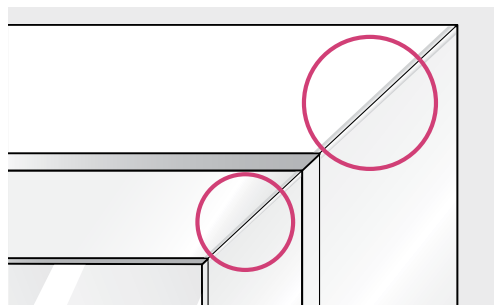

WELDED LEAK-PROOF CORNERS

- Strengthened frames and sashes
- Impede leaks

Max protection against dust and water

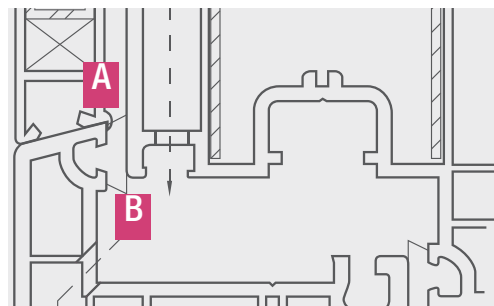

PROTECTIVE SEALS

- EPDM dual compression seals act as an excellent barrier against air and sound infiltration
- Allows water to drain efficiently

- A** 8mm overlap of frame and sash
- B** Gasket

*Compared to standard aluminum windows

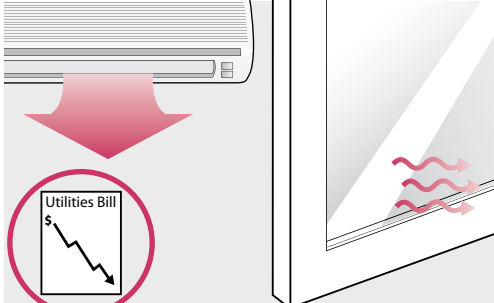

EXCELLENT THERMAL INSULATION

- Heavily reduced electricity bills
- Prevents heat transfer from inside to outside thereby reducing energy expended to cool your room

U-value* of up to 1.6 possible

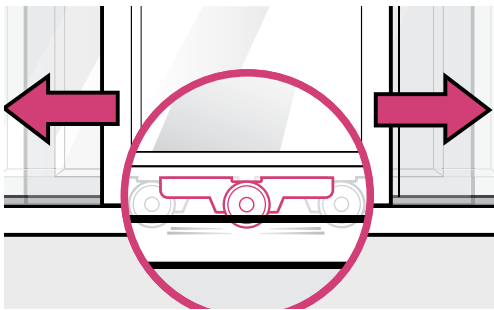

SMOOTH AND EFFORTLESS SLIDING

This is facilitated by:

- Specially formulated aluminium tracks
- Premium quality, durable, low friction rollers

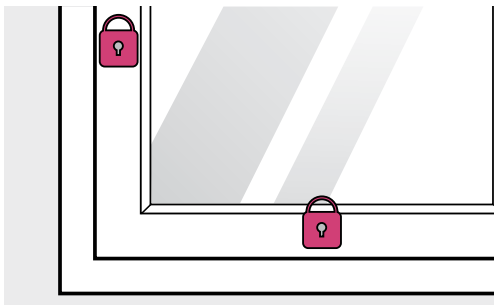

IMPROVED SECURITY

- Eurogroove positioned through the centre of the sash profile
- Designed with firm locking position for multi-point locking gears, thus enhancing the resistance to forced entry
- Sturdy, steel reinforced profiles made of impacted tested recipe

Provides strong resistance to forced entry

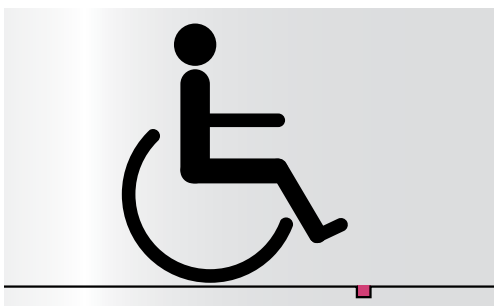

LOW THRESHOLD FOR DOORS

- Low threshold for wheelchair access
- Satisfying most building requirements and regulations

*U-value is the measure of heat that passes through a window. The lower the U-value, the better the windows. All systems (non-thermally broken) have U-values around 5.

COMPLETE PROVIDER OF QUALITY SOLUTIONS

YOUR ONE-STOP SHOP TO EXECUTE PROJECTS END-TO-END

REHAU Support for Fabricators and Installers

START-UP

- Material and equipment
- Equipment selection and provision
- Production and sales staff training
- Plant layout advice
- Inventory management assistance

MARKETING

- Refresher course on product selling for sales team
- Product marketing consultation support and advisory
- Advertising and branding support, including use of REHAU Quality Window Design Logo

OPERATION

- Plant audit
- Process audit
- Site installation audit
- Refresher production workshops
- REHAU newsletter and Windows bulletin
- Online consultancy



REHAU assurance and support

REHAU is committed to **excellence and quality** in both its products and people. We **listen** so we can offer precise and customised solutions that suit your market's needs.

Apart from quality reflected by our products, it is further highlighted in the support we provide. Our team of international and local experts are at your disposal providing free business consultancy, continuous support and training.





HIGHLY TRAINED NETWORK OF FABRICATORS AND INSTALLERS

Each authorised REHAU window fabricator will enjoy not only profiles of the **highest quality**, but also **marketing and promotional advantages** customised to help you build your new REHAU business.

The REHAU Academy provides **in-depth training** to ensure that our fabricators know their merchandise inside out.



TECHNICAL SUPPORT

We recognise that a successful solution requires the right tools, the know-how of an experienced team and the desire to create a product that exceeds customers' expectations. At REHAU, we help our partners to achieve their goals from project planning to job-site support via the **REHAU Competence Team**. Contact us through your nearest REHAU sales office listed on the back of the brochure.



YOUR PERFECT LONG-TERM PARTNER

We offer you the strength of a world-leading brand of polymer-based solutions. One that is backed by **outstanding innovations**, the most modern manufacturing technologies and flexible logistics. You'll discover in REHAU a future-oriented and **reliable partner** with a **width and depth of expertise** second to none.



THE REHAU SHOWCASE

DELIVERING QUALITY AND PERFORMANCE





When it comes to style and range of windows, REHAU has left few stones unturned. Everything from inward and outward opening windows, single windows to multi light windows with transoms, sliding windows and doors, balcony doors as well as solutions for conservatories. French doors, arched windows, non-rectangular constructions or Georgian bars - the creativity possibilities are virtually unlimited!



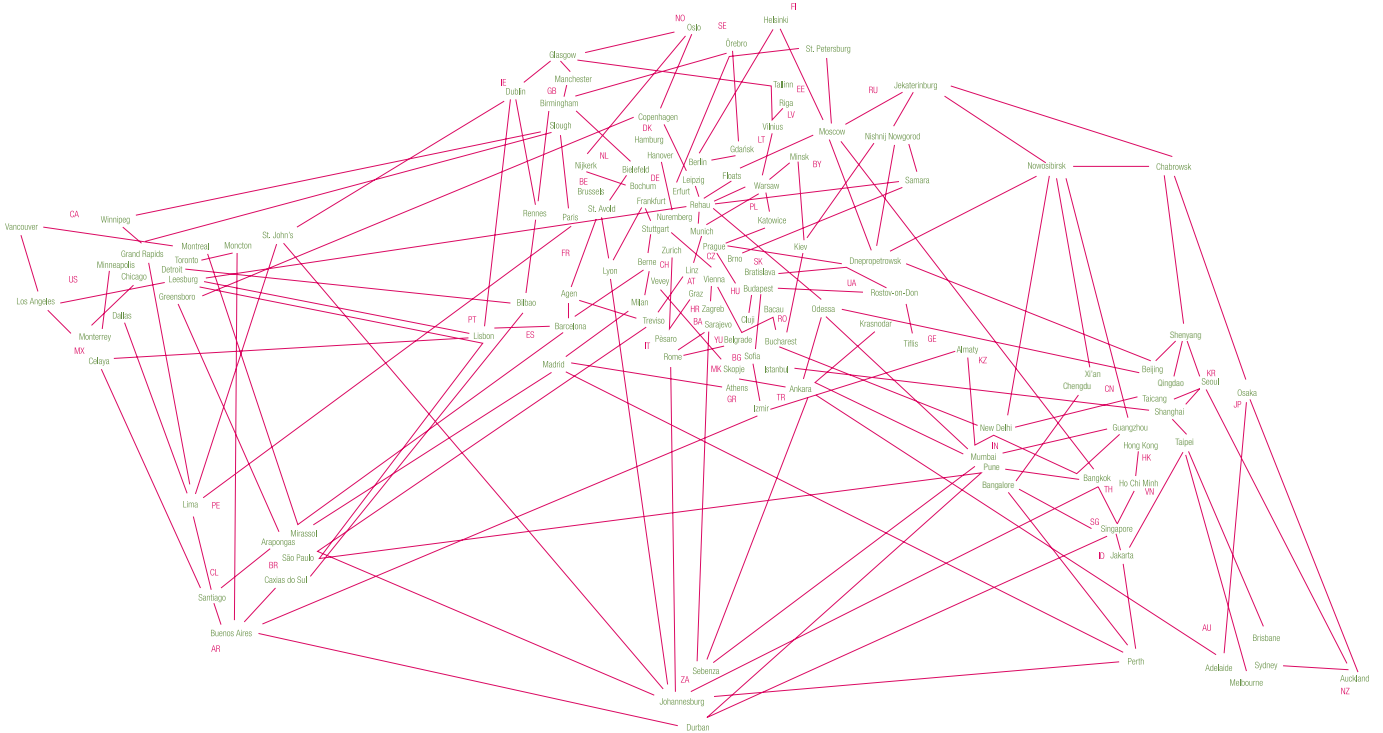

Our verbal and written advice relating to technical applications is based on experience and is to the best of our knowledge correct but is given without obligation. The use of REHAU products in conditions that are beyond our control or for applications other than those specified releases us from any obligation in regard to claims made in respect of the products. We recommend that the suitability of any REHAU product for the intended application should be checked. Utilization and processing of our products are beyond our control and are therefore exclusively your responsibility. In the event that a liability is nevertheless considered, any compensation will be limited to the value of the goods supplied by us and used by you. Our warranty assumes consistent quality of our products in accordance with our specification and in accordance with our general conditions of sale. This document is protected by copyright. All rights based on this are reserved. No part of this publication may be translated, reproduced or transmitted in any form or by any similar means, electronic or mechanical, photocopying, recording or otherwise, or stored in a data retrieval system.

REHAU Branches in Asia/Australia

Regional Office for Asia/Australia
SINGAPORE

1 King George's Avenue, REHAU Building, Singapore 208557 Tel: +65 6392-6006 Fax: +65 6392-6116

AUSTRALIA National Customer Centre Tel: 1300 768 033 Adelaide Tel: +61 8 8100-3500 Brisbane Tel: +61 7 5527-1833 Melbourne Tel: +61 3 9586-3100 Perth Tel: +61 8 9456-0700 Sydney Tel: +61 2 8741-4500 **GREATER CHINA** Beijing Tel: +86 10 6428-2956 Chengdu Tel: +86 28 8628-3218 Guangzhou Tel: +86 20 8776-0343 / 3646 Hong Kong Tel: +852 2898-7080 Qingdao Tel: +86 532 8667-8190 Shenyang Tel: +86 24 2287-5807 Taicang Tel: +86 512 5337-2815 Taipei Tel: +886 2 8780-3899 Xi'an Tel: +86 29 6859-7000 **INDIA** Bangalore Tel: +91 80 2222-0014 ~ 0015 Mumbai Tel: +91 22 6148-5858 New Delhi Tel: +91 11 4504-4700 ~ 4705 Pune Tel: +91 21 3530-4801 **INDONESIA** Jakarta Tel: +62 21 5275-177 **JAPAN** Tokyo Tel: +81 3 5796-2102 **KOREA** Seoul Tel: +82 2 5011-656 **NEW ZEALAND** Auckland Tel: +64 9 2722-264 **THAILAND** Bangkok Tel: +66 2 7443-155 **VIETNAM** Ho Chi Minh City Tel: +84 8 3823-3030